

- 1
- 2
- 3
- 4
- 5
- 6
- 7
- 8
- 9
- 10
- 11
- 12
- 13
- 14
- 15
- 16
- 17
- 18

**BASE AND STEM**  
AISI 304 stainless steel.

**ELASTIC RING**  
AISI 301 stainless steel.

**STANDARD EXECUTIONS**

- **GN 6311.6-N:** base without no-slip disk.
- **GN 6311.6-R:** base with thermoplastic elastomer (TPE) no-slip coating, black colour.
- **GN 6311.6-G:** base with acetal based (POM) technopolymer bearing protection, RAL 9001 natural white colour.

**FEATURES AND APPLICATIONS**  
Stainless steel levelling feet GN 6311.6 are used for installing and levelling devices and equipment.  
The values listed in the table refer to an axial load in relation to the levelling foot.  
Under normal operating conditions, any lateral or angular stresses that may result in a reduction of load capacity must be taken into consideration.

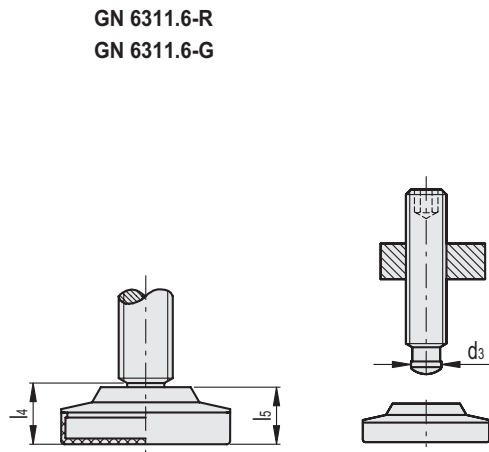
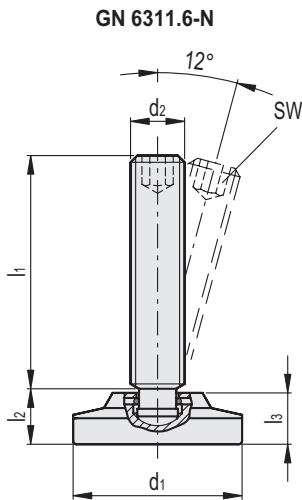

**GN 6311.6-N**

Code	Description	d1	d2	d3	l1	l2	l3	l4	l5	sw	Static load [kN]	⚖️
GN.16033	GN 6311.6-50-M10-37-N	50	M 10	8	37	12.5	11.5	14	13	5	14	155
GN.16036	GN 6311.6-50-M10-47-N	50	M 10	8	47	12.5	11.5	14	13	5	14	159
GN.16039	GN 6311.6-50-M10-57-N	50	M 10	8	57	12.5	11.5	14	13	5	14	165
GN.16042	GN 6311.6-50-M10-72-N	50	M 10	8	72	12.5	11.5	14	13	5	14	179
GN.16047	GN 6311.6-50-M12-41-N	50	M 12	8	41	12.5	11.5	14	13	5	14	165
GN.16050	GN 6311.6-50-M12-51-N	50	M 12	8	51	12.5	11.5	14	13	5	14	174
GN.16053	GN 6311.6-50-M12-61-N	50	M 12	8	61	12.5	11.5	14	13	5	14	178
GN.16056	GN 6311.6-50-M12-71-N	50	M 12	8	71	12.5	11.5	14	13	5	14	185
GN.16059	GN 6311.6-50-M12-91-N	50	M 12	8	91	12.5	11.5	14	13	5	14	201
GN.16062	GN 6311.6-50-M16-59-N	50	M 16	12	59	14.5	13.5	16	15	8	33	227
GN.16065	GN 6311.6-50-M16-69-N	50	M 16	12	69	14.5	13.5	16	15	8	33	236
GN.16068	GN 6311.6-50-M16-89-N	50	M 16	12	89	14.5	13.5	16	15	8	33	260
GN.16071	GN 6311.6-50-M16-114-N	50	M 16	12	114	14.5	13.5	16	15	8	33	295
GN.16074	GN 6311.6-60-M16-59-N	60	M 16	12	59	14.5	13.5	16	15	8	33	313
GN.16077	GN 6311.6-60-M16-69-N	60	M 16	12	69	14.5	13.5	16	15	8	33	322
GN.16080	GN 6311.6-60-M16-89-N	60	M 16	12	89	14.5	13.5	16	15	8	33	346
GN.16083	GN 6311.6-60-M16-114-N	60	M 16	12	114	14.5	13.5	16	15	8	33	381
GN.16087	GN 6311.6-60-M20-78-N	60	M 20	15.5	78	16.5	15.5	18	17	10	55	409
GN.16090	GN 6311.6-60-M20-88-N	60	M 20	15.5	88	16.5	15.5	18	17	10	55	427
GN.16093	GN 6311.6-60-M20-113-N	60	M 20	15.5	113	16.5	15.5	18	17	10	55	472
GN.16096	GN 6311.6-60-M20-138-N	60	M 20	15.5	138	16.5	15.5	18	17	10	55	523

## GN 6311.6-R

INOX STAINLESS STEEL

Code	Description	d1	d2	d3	l1	l2	l3	l4	l5	s	sw	Static load [kN]	
GN.16031	GN 6311.6-50-M10-37-R	50	M 10	8	37	12.5	11.5	14	13	2	5	13	138
GN.16034	GN 6311.6-50-M10-47-R	50	M 10	8	47	12.5	11.5	14	13	2	5	13	142
GN.16037	GN 6311.6-50-M10-57-R	50	M 10	8	57	12.5	11.5	14	13	2	5	13	148
GN.16040	GN 6311.6-50-M10-72-R	50	M 10	8	72	12.5	11.5	14	13	2	5	13	163
GN.16045	GN 6311.6-50-M12-41-R	50	M 12	8	41	12.5	11.5	14	13	2	6	13	148
GN.16048	GN 6311.6-50-M12-51-R	50	M 12	8	51	12.5	11.5	14	13	2	6	13	157
GN.16051	GN 6311.6-50-M12-61-R	50	M 12	8	61	12.5	11.5	14	13	2	6	13	161
GN.16054	GN 6311.6-50-M12-71-R	50	M 12	8	71	12.5	11.5	14	13	2	6	13	168
GN.16057	GN 6311.6-50-M12-91-R	50	M 12	8	91	12.5	11.5	14	13	2	6	13	184
GN.16060	GN 6311.6-50-M16-59-R	50	M 16	12	59	14.5	13.5	16	15	2	8	30	207
GN.16063	GN 6311.6-50-M16-69-R	50	M 16	12	69	14.5	13.5	16	15	2	8	30	216
GN.16066	GN 6311.6-50-M16-89-R	50	M 16	12	89	14.5	13.5	16	15	2	8	30	240
GN.16069	GN 6311.6-50-M16-114-R	50	M 16	12	114	14.5	13.5	16	15	2	8	30	275
GN.16072	GN 6311.6-60-M16-59-R	60	M 16	12	59	14.5	13.5	16	15	2	8	30	284
GN.16075	GN 6311.6-60-M16-69-R	60	M 16	12	69	14.5	13.5	16	15	2	8	30	293
GN.16078	GN 6311.6-60-M16-89-R	60	M 16	12	89	14.5	13.5	16	15	2	8	30	317
GN.16081	GN 6311.6-60-M16-114-R	60	M 16	12	114	14.5	13.5	16	15	2	8	30	352
GN.16085	GN 6311.6-60-M20-78-R	60	M 20	15.5	78	16.5	15.5	18	17	2	10	50	379
GN.16088	GN 6311.6-60-M20-88-R	60	M 20	15.5	88	16.5	15.5	18	17	2	10	50	397
GN.16091	GN 6311.6-60-M20-113-R	60	M 20	15.5	113	16.5	15.5	18	17	2	10	50	442
GN.16094	GN 6311.6-60-M20-138-R	60	M 20	15.5	138	16.5	15.5	18	17	2	10	50	493

## GN 6311.6-G

INOX STAINLESS STEEL

Code	Description	d1	d2	d3	l1	l2	l3	l4	l5	s	sw	Static load [kN]	
GN.16032	GN 6311.6-50-M10-37-G	50	M 10	8	37	12.5	11.5	14	13	2	5	14	150
GN.16035	GN 6311.6-50-M10-47-G	50	M 10	8	47	12.5	11.5	14	13	2	5	14	154
GN.16038	GN 6311.6-50-M10-57-G	50	M 10	8	57	12.5	11.5	14	13	2	5	14	160
GN.16041	GN 6311.6-50-M10-72-G	50	M 10	8	72	12.5	11.5	14	13	2	5	14	174
GN.16046	GN 6311.6-50-M12-41-G	50	M 12	8	41	12.5	11.5	14	13	2	6	14	160
GN.16049	GN 6311.6-50-M12-51-G	50	M 12	8	51	12.5	11.5	14	13	2	6	14	169
GN.16052	GN 6311.6-50-M12-61-G	50	M 12	8	61	12.5	11.5	14	13	2	6	14	173
GN.16055	GN 6311.6-50-M12-71-G	50	M 12	8	71	12.5	11.5	14	13	2	6	14	180
GN.16058	GN 6311.6-50-M12-91-G	50	M 12	8	91	12.5	11.5	14	13	2	6	14	196
GN.16061	GN 6311.6-50-M16-59-G	50	M 16	12	59	14.5	13.5	16	15	2	8	33	217
GN.16064	GN 6311.6-50-M16-69-G	50	M 16	12	69	14.5	13.5	16	15	2	8	33	226
GN.16067	GN 6311.6-50-M16-89-G	50	M 16	12	89	14.5	13.5	16	15	2	8	33	250
GN.16070	GN 6311.6-50-M16-114-G	50	M 16	12	114	14.5	13.5	16	15	2	8	33	285
GN.16073	GN 6311.6-60-M16-59-G	60	M 16	12	59	14.5	13.5	16	15	2	8	33	304
GN.16076	GN 6311.6-60-M16-69-G	60	M 16	12	69	14.5	13.5	16	15	2	8	33	313
GN.16079	GN 6311.6-60-M16-89-G	60	M 16	12	89	14.5	13.5	16	15	2	8	33	337
GN.16082	GN 6311.6-60-M16-114-G	60	M 16	12	114	14.5	13.5	16	15	2	8	33	372
GN.16086	GN 6311.6-60-M20-78-G	60	M 20	15.5	78	16.5	15.5	18	17	2	10	55	400
GN.16089	GN 6311.6-60-M20-88-G	60	M 20	15.5	88	16.5	15.5	18	17	2	10	55	418
GN.16092	GN 6311.6-60-M20-113-G	60	M 20	15.5	113	16.5	15.5	18	17	2	10	55	463
GN.16095	GN 6311.6-60-M20-138-G	60	M 20	15.5	138	16.5	15.5	18	17	2	10	55	514